



Croce Rossa Italiana

# CROCE ROSSA ITALIANA

Corso di formazione  
RISCHIO IDROGEOLOGICO E IDROLOGICO

## Barriere mobili per arginare le inondazioni

Giuseppe Bolzoni  
Emergency Manager



Per evitare l'allagamento delle abitazioni, l'arginatura con sacchi di sabbia è il tipo di barriera più conosciuto.



Oltre ai sacchi, esistono altri tipi di barriere mobili passive

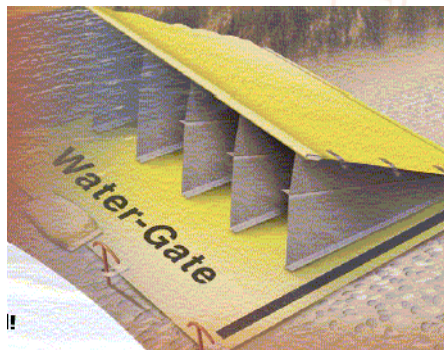

Stesura di una barriera anti-allagamento



Barriera antiallagamento in attività



Stesura di una barriera antiallagamento



Sono ottime anche per i sopralzi arginali

Come funziona una barriera passiva antiallagamento

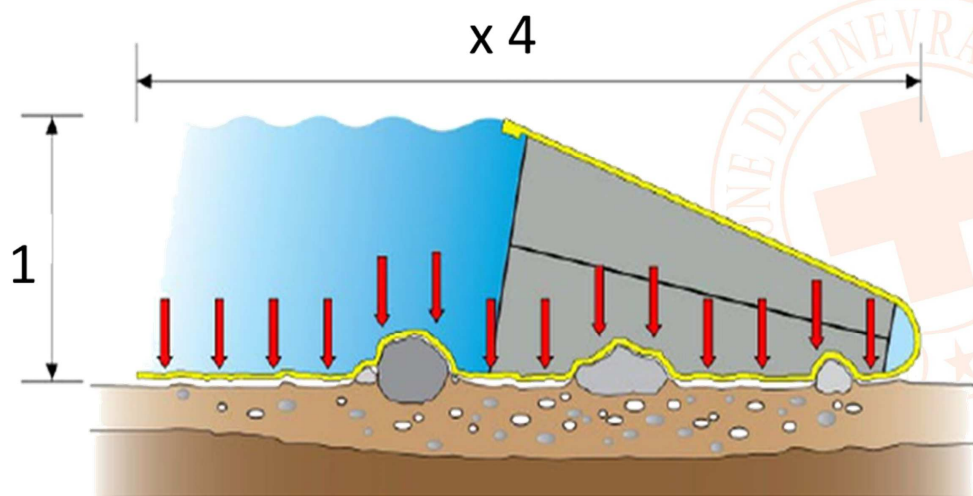

Barriera rigida antiallagamento



Secondo il fornitore, queste barriere sono montabili anche con esondazione in corso

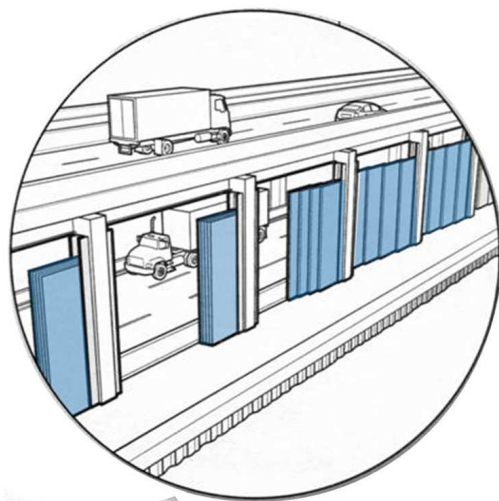

Barriere mobili a protezione di una autostrada

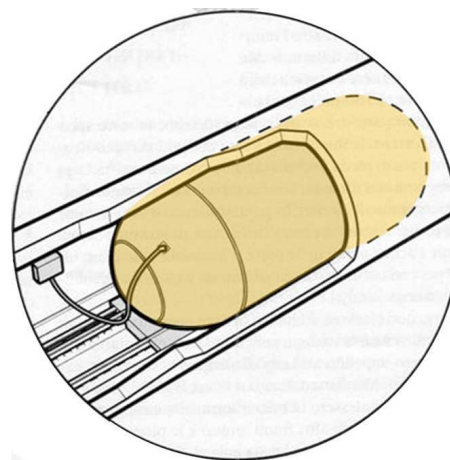

Proposta di chiusura pneumatica dei tunnel della metropolitana nella città di New York

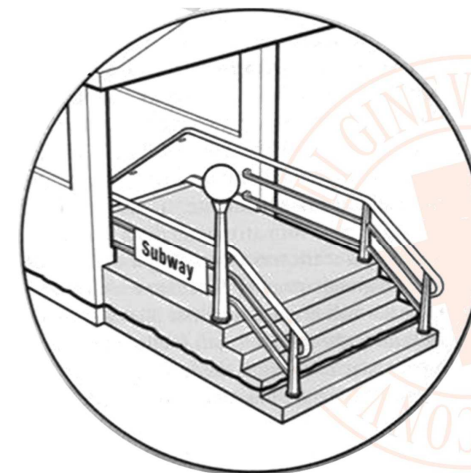

Innalzamento del livello di ingresso alle stazioni del metrò

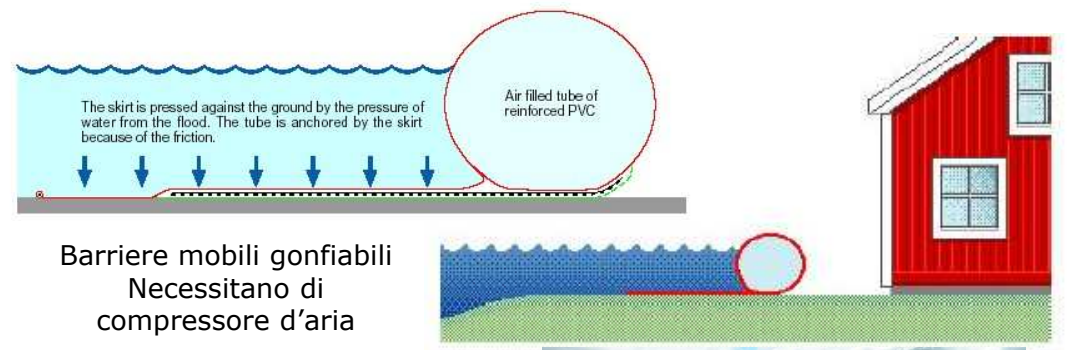
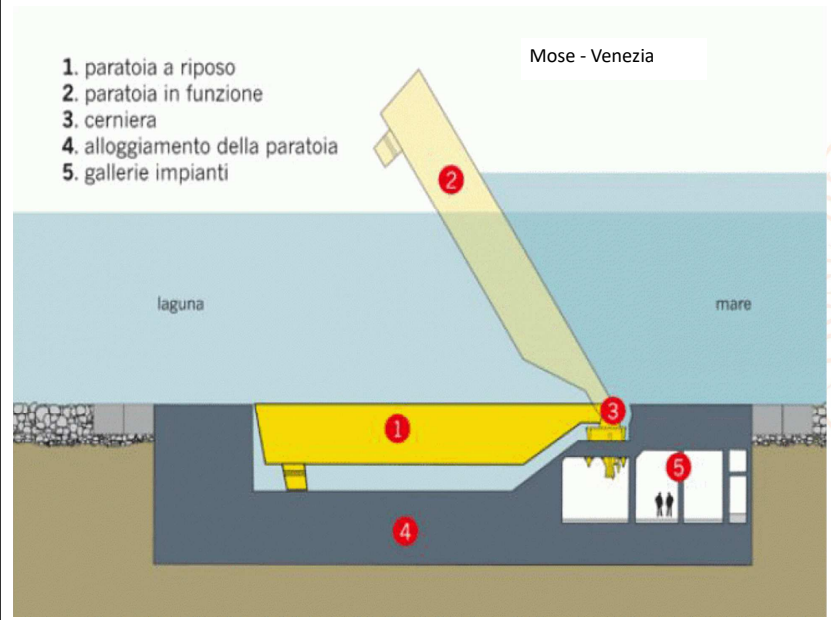
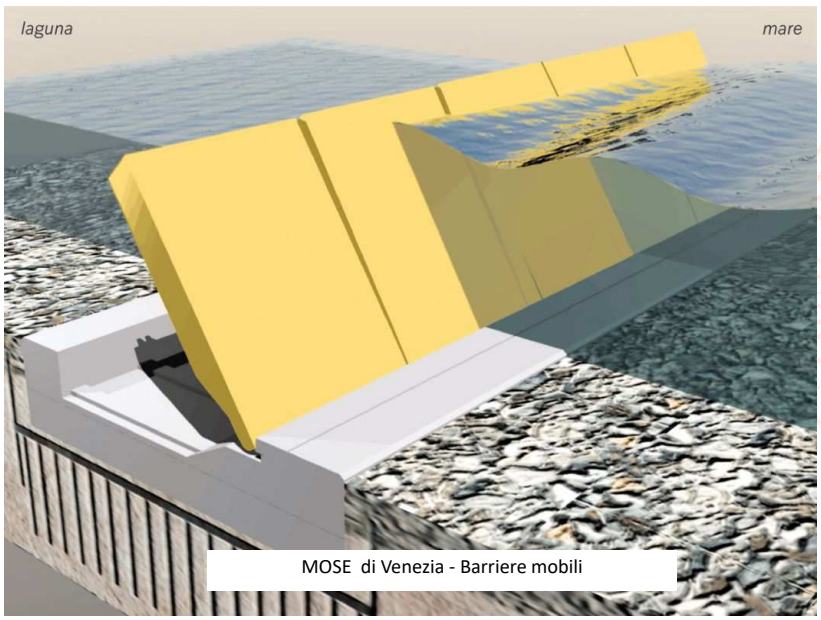

Alcune applicazioni



Protezione di aree residenziali o di impianti cruciali



Sopralzo per arginature esistenti

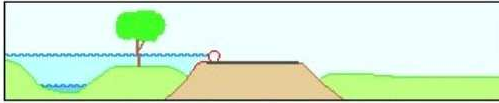

Protezione di strade da erosione delle correnti



Mantenere percorribili importanti vie di comunicazione

Barriere mobili con  
cordoli di tessuto  
non tessuto riempiti  
di sabbia

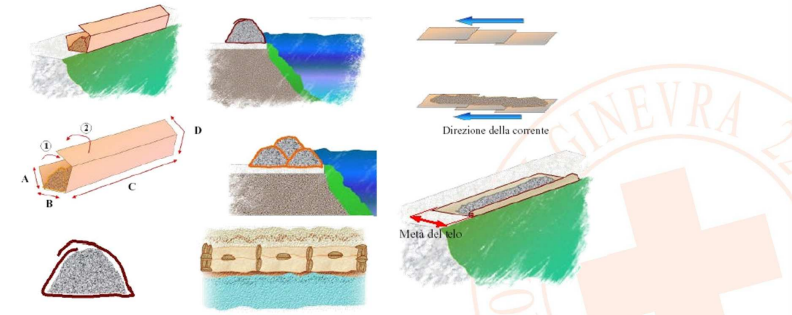

Barriere mobili QUICK DAMM  
si possono riempire anche lontano dal punto di  
posizionamento o con acqua





Le barriere di protezione si chiudono al sopraggiungere della piena.

Al termine dell'emergenza, la barriera viene ritratta e scompare.



Per essere efficaci, le devono essere collegate con ulteriori protezioni. Nella figura si nota il muretto di contenimento intorno alla casa.



Queste barriere a scomparsa possono essere utilizzate per proteggere strade o passaggi (ad esempio le aperture nei sopralti arginali fissi).

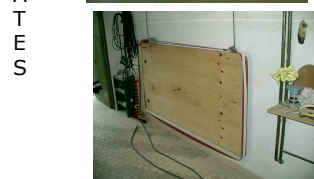

D  
O  
O  
R  
G  
A  
T  
E  
S



I sacconi riempiti con sabbia sono molto utili per bloccare i rigurgiti di fognatura in cortili e piazzali o per costruire barriere.



File di sacconi riempiti di sabbia possono essere utilizzati per preparare arginature in alternativa ai sacchi di sabbia. Queste barriere possono contenere fino ad un metro d'acqua e sono molto efficaci.



Sacchi di sabbia utilizzati a protezione di una spiaggia dalle mareggiate



Barriere rivierasche antierosione in aree soggette ad uragani



Barriere rivierasche antierosione in aree soggette ad uragani

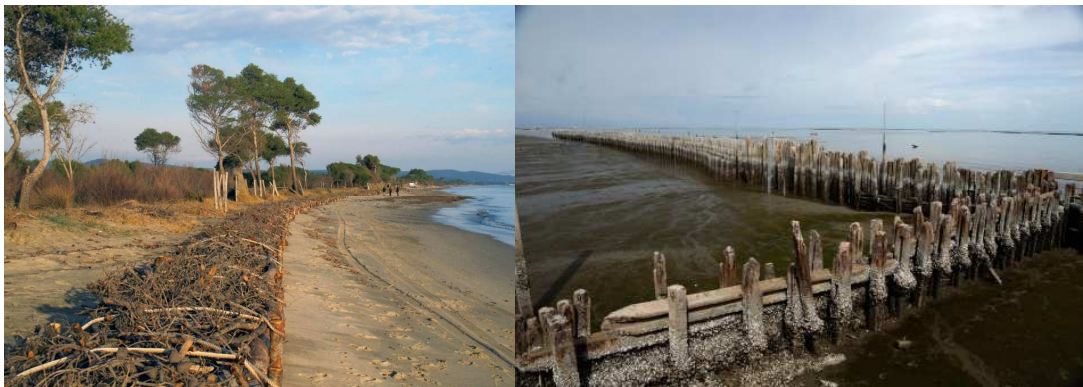

I sacchi di Nylon con polimeri che si rigonfiano, anche se molto comodi, è meglio evitarli perché, dopo il rigonfiamento, avendo la densità simile o inferiore a quella dell'acqua di piena, possono essere facilmente spostati dalla forza della stessa.



# ULTIMATE FLOOD BAG DEFENDER

REUSABLE FLOOD DEFENCE BAGS



Super  
absorbent  
polymer gel  
expands on  
contact with  
water



- ◆ Fast protection for your property
- ◆ Reusable and environmentally friendly
- ◆ Quick & easy
- ◆ No sand required
- ◆ No tools required



**Grazie per l'attenzione**